

4. Frying

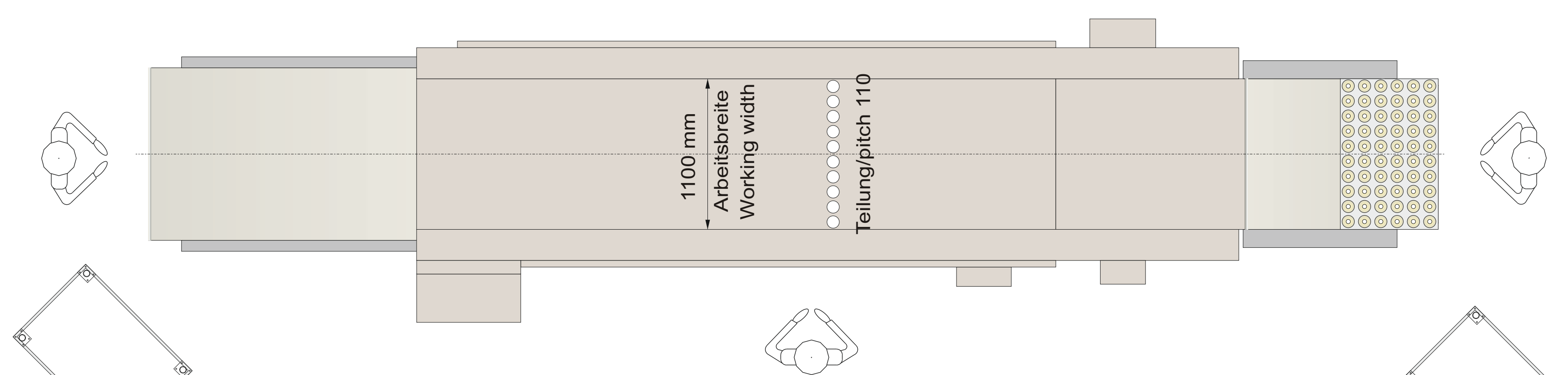

5. Manual finishing

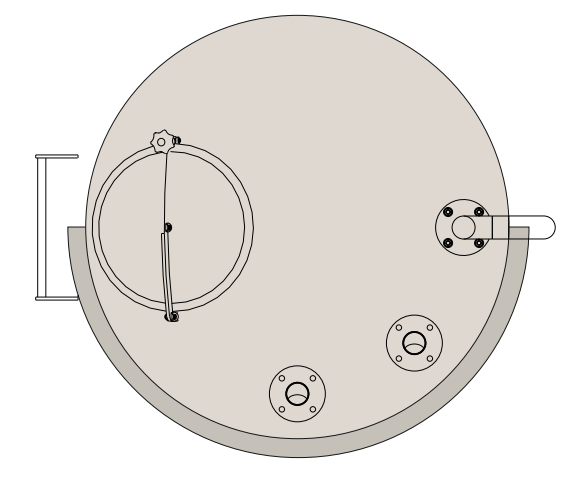
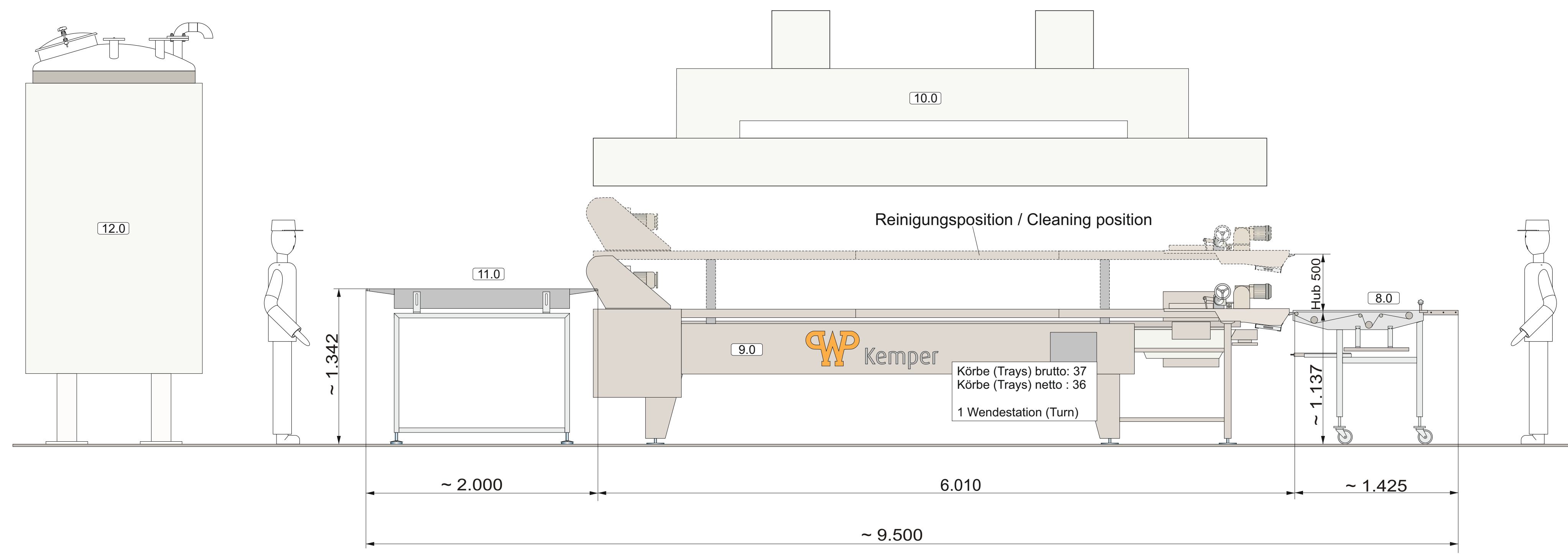
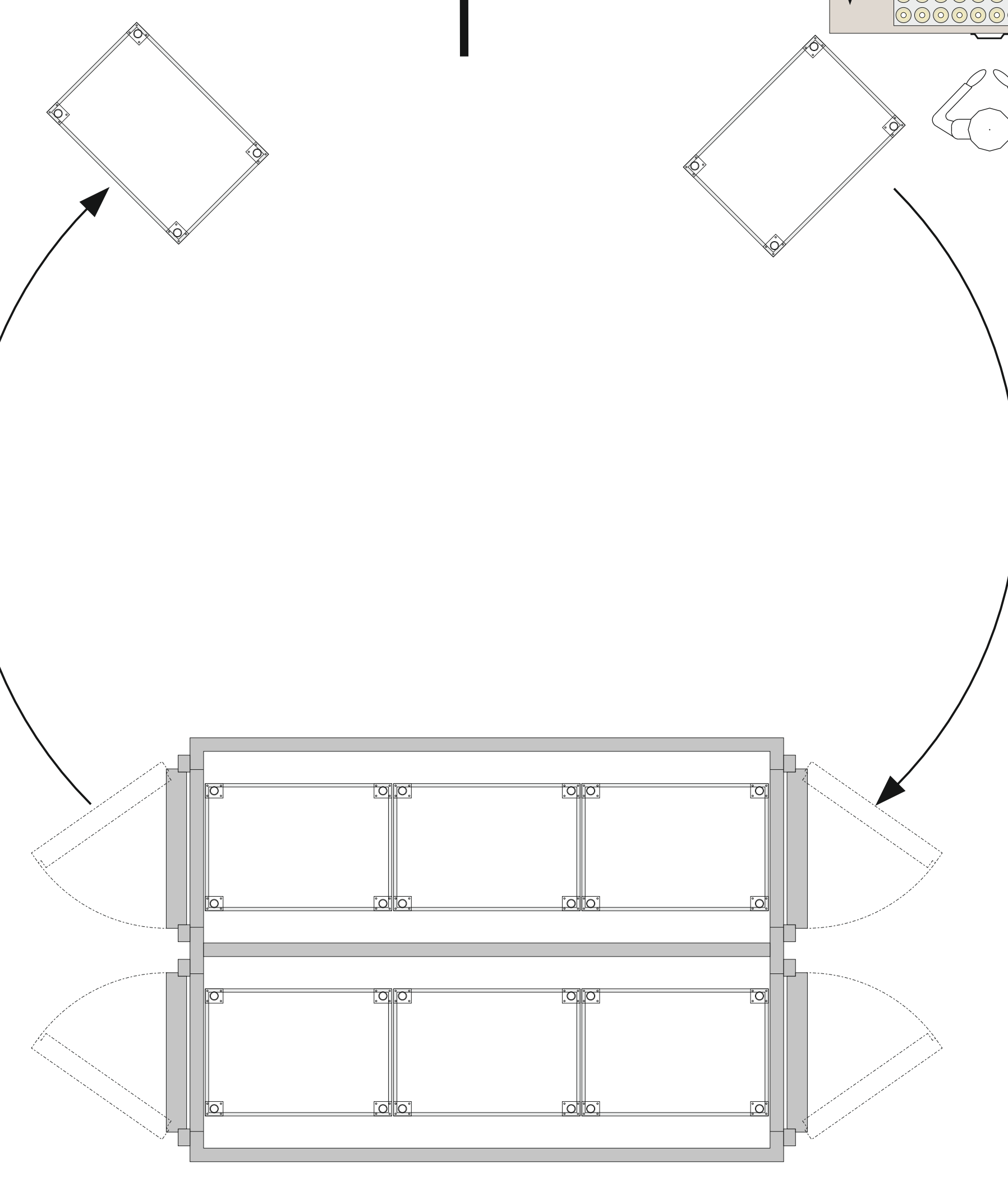
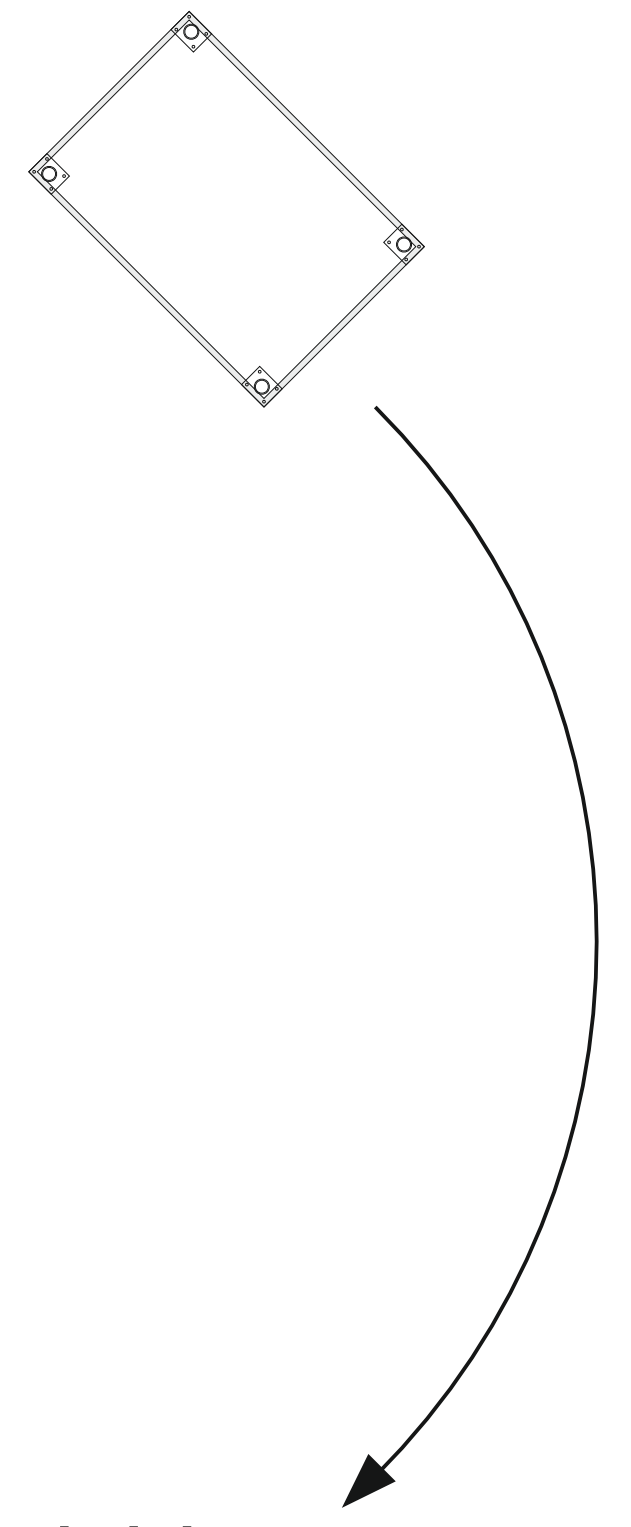

3. Final proofing

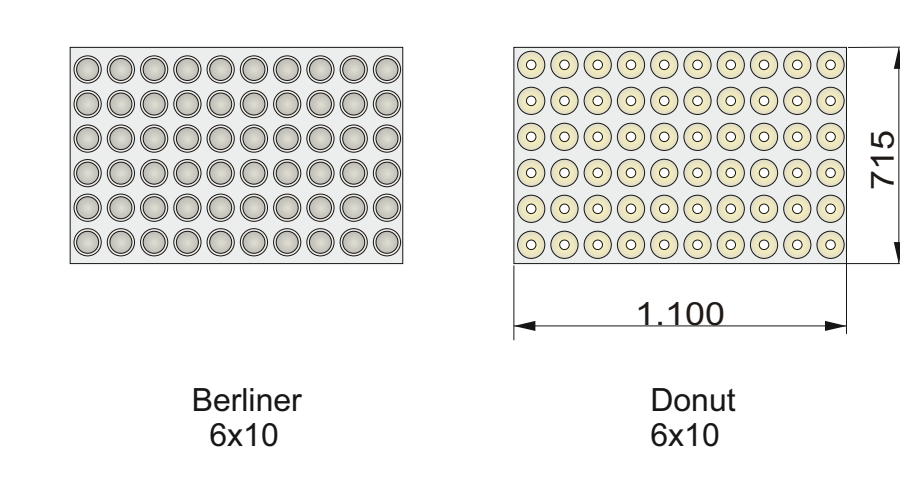

2. Donut make up

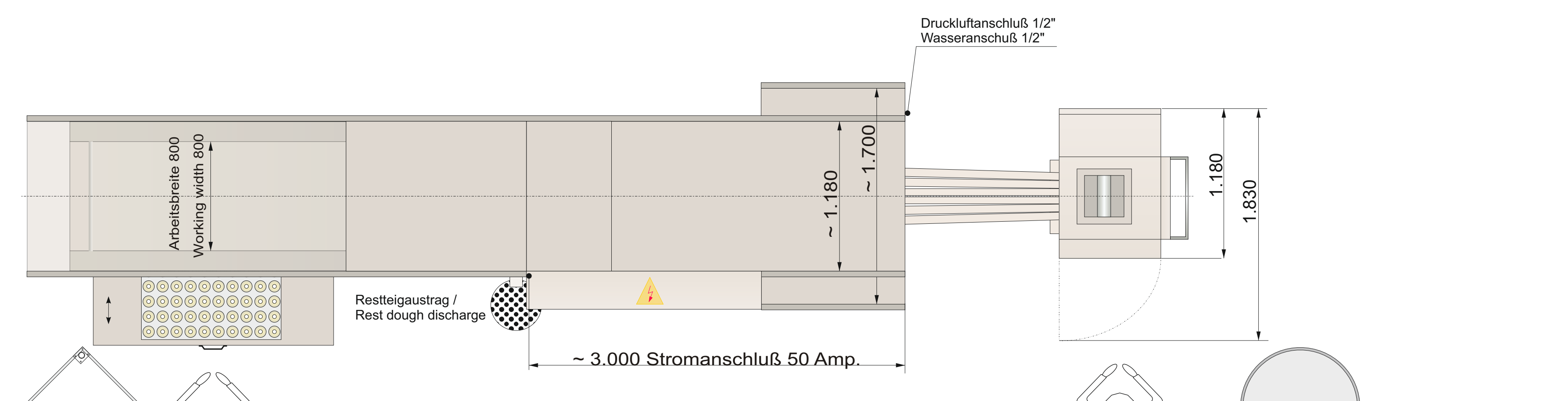
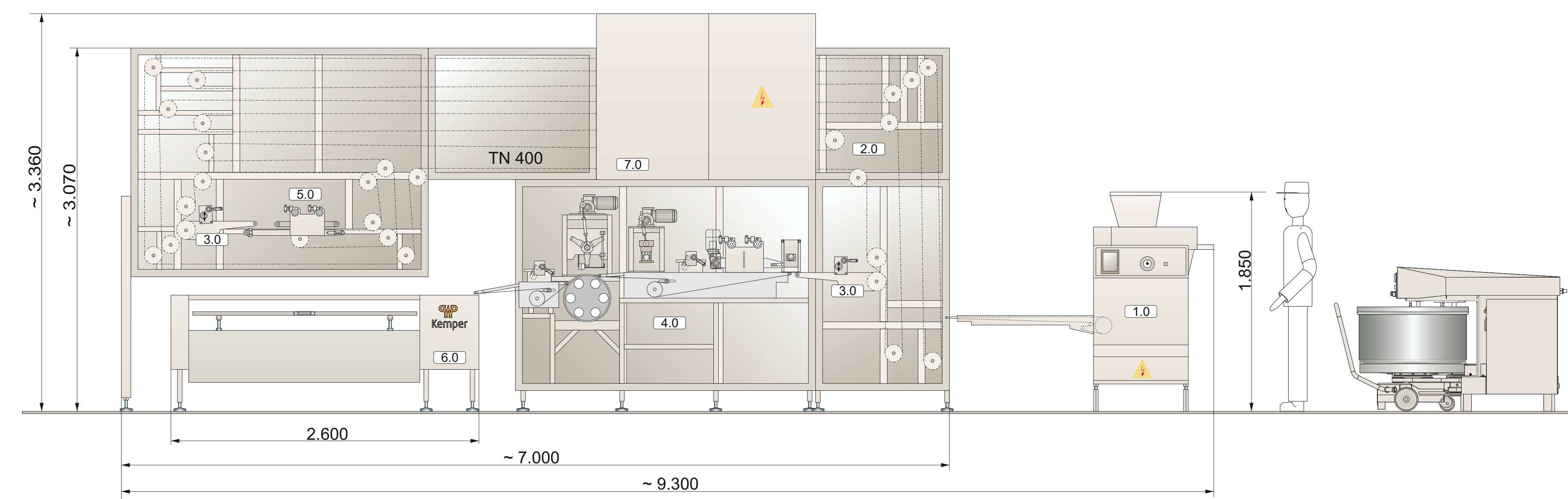

1. Mixing

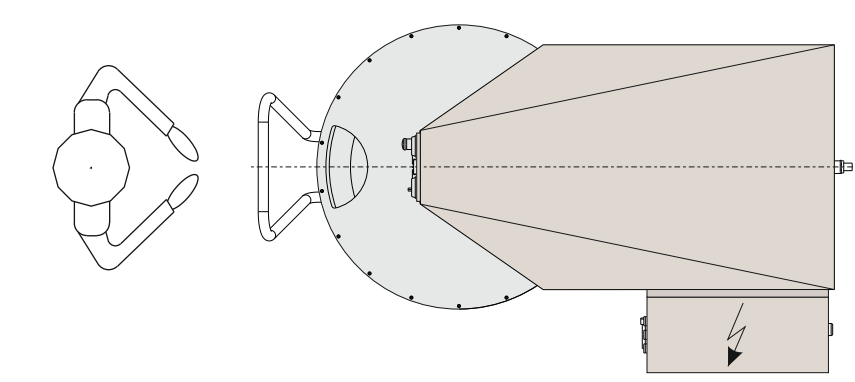

Kunde/Customer: Kemper Intern

			Technische Daten	Donut	Berliner		
			Anlage	6-reihig / 6 row	6-reihig / 6 row		
			Fettbackautomat	10-reihig / 10 row	10-reihig / 10 row		
12.0	Arbeitstank	Work tank	Stundenleistung	ca (Stück)	7.200	3.500	
11.0	Transportband	Transport belt	Fettbackkapazität (Piece)				
10.0	Abseughäube	Exhaust hood	Teiggewichtsbereich (g)	40 - 50	50 - 60		
9.0	Fettbackautomat	Frying System	Dough weight range (g)				
8.0	Tuchaufgabeband fahrbar	Cloth charging belt	Bäckzeit (sec)	180	360		
7.0	Schaltschrank	Switch box	Baking time (sec)				
6.0	Abzugsband	Discharge belt	Zwischengare (min)				
5.0	Langwerkstation	Longloading station	Intermediate proof (min)				
4.0	Stanzstation für Donutteilglinge	Punching station for ring donut pieces	Final proof (min)				
3.0	Austrageband	Discharging belt	Endgare (min)				
2.0	Gänsschrank	Intermediate proofer					
1.0	Multimatic	Multimatic					
Anlage, bestehend aus:			Plant consists of:				

Angabens-Nr. / Offer No. 586213A2
 Artikel-Nr. / Article No. ZB 15-86-150
 Datum / Date. 01.09.2015
 Name / Name Kordtomeikel
 Maßstab / Scale 1:25
 Dateiname / File name 586213A2

Das Urheberrecht an dieser Zeichnung gehört uns. Jede Vervielfältigung, Verbreitung und Nutzung ist ohne schriftliche Genehmigung der Kemper GmbH ist strafbar. The copyright of this drawing belongs to us. Any reproduction or communication of this drawing to third persons is, according to copyright law, competition law and Civil Code, prohibited and liable to prosecution.

Technische Änderungen vorbehalten ! / The right is reserved to make technical amendments !

